

WelHandy Multi



The “Multi” stand for Multiple Welding Operations. The Wel Handy Multi can be delivered with two types of controllers and two options, which makes it versatile.

The welding operations are:

*Horizontal Fillets Welding,
Vertical Down/up Fillets Welding ,
Flat Butt Joint Welding (with rail),
Horizontal Butt Joint Welding (with rail),
Twin Torch
Longitudinal simultaneous welding both side
Tandem welding
Tack Welding
Adapt to the Weaving Device*

WelHandy Multi II

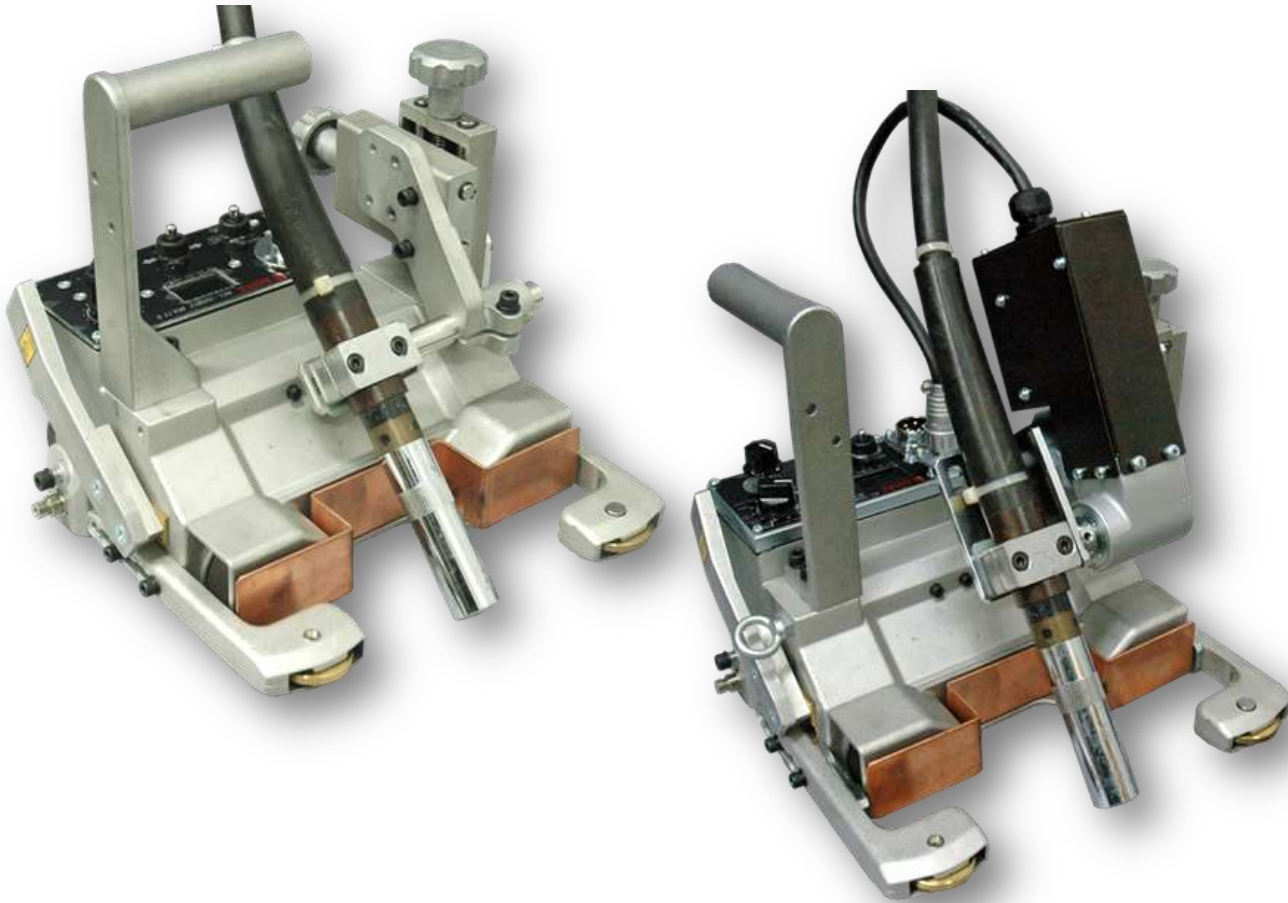

WEL-HANDY MULTI-II TACK: Tack welding

WEL-HANDY MULTI-II WEAVING: Tack and Weaving welding

NEW - Advanced controller tack welding is standard, and distance of welding and dry-run can be controlled manually during welding. Crater function as standard.

NEW - Limit switch function has dry-run function, which makes positioning of the carriage possible without lifting. (Patent pending)

NEW - Encoder drive motor and control ensures precise speed control during welding.

NEW - Weaving control (only for weaving model) Weaving parameter is adjustable during welding. Easy operation with dial control.

NEW - Tack welding and weaving changes at the same time no stopping while welding

SAME - Reliability, Robustness and Durability.

WelHandy Multi II

Major changes have been made to the operation panel and drive unit to greatly improve travel speed accuracy and operation ability.

Current operation panel



NEW operation panel



WelHandy Multi II

Parameter adjustable during weaving!

Weaving parameters (weaving width, speed, wait time, torch positioning, etc) could not be adjusted during welding with the old type controller.

Weaving parameters can be adjusted during welding!

Width maximum 180 gr!

With the multi functional dial, instead of panel buttons,

Parameters can be adjusted much easier.

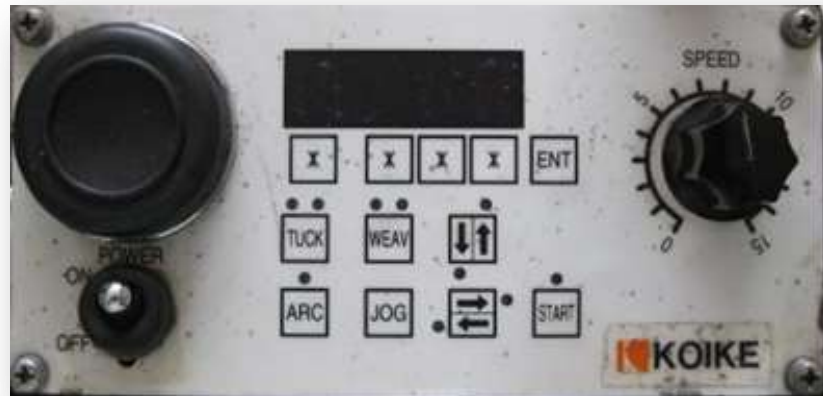



Magnet On/Off

Lift Handel



Torch Adjuster



Guide Rollers



Limit Switches

Bottom Stainless Heat Shield
All Wheel Dive System



Torch Holder

WelHandy Multi II

Easy rail Option

Flat Butt/Lap Joint Welding.
Horizontal Butt/Lap Joint Welding.

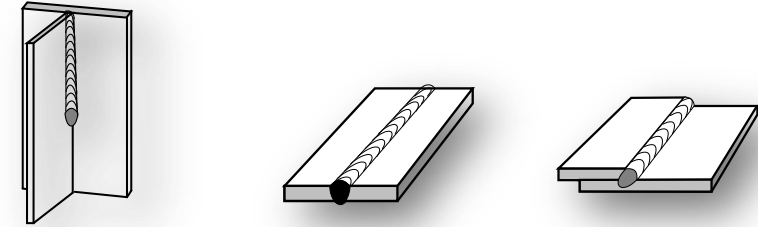

Twin Torch Option

Longitudinal simultaneous Welding both side.
Tandem Welding.

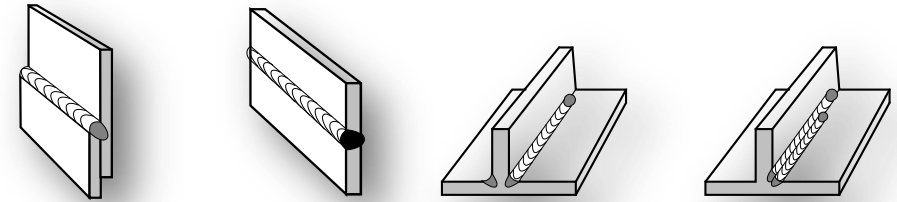

Tack Welding Version (standard on all types)

True distance tack welding

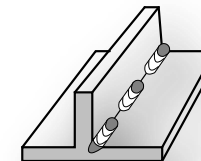

Weaving

Large multiple and single pass welding up to 25mm



Optimum use in welding needs

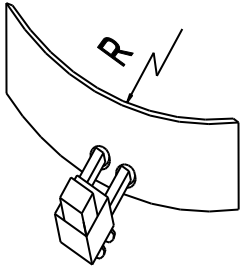

OR=3,000mm

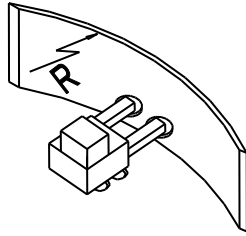

IR=3,000mm

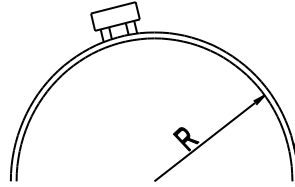

R=1,000mm

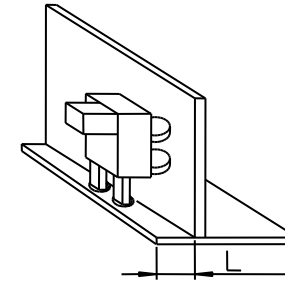
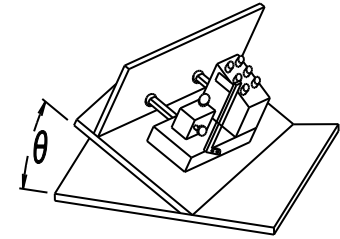
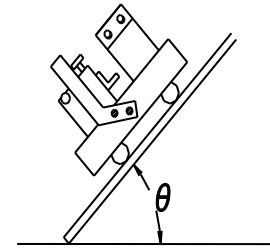

L=More than 40mm

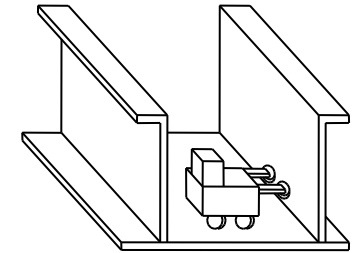

Minimum 300mm

Selectable parts for different welding positions

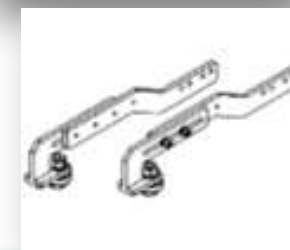
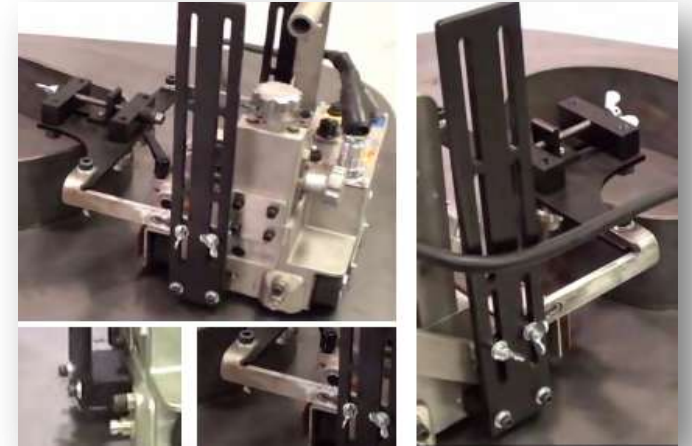

WelHandy Multi II



Welding speed	50 – 1500 mm/min, left and right
Drive	4 WD
Controler	NEW - <u>Advanced controller tack welding</u> is standard, and distance of welding and dry-run can be controlled manually during welding. Crater function as standard, weaving as option
Magnet	50 KG magnet
Torch holder	vertical and horizontal stroke 45 dg adjustable
Guide weel	Adjustable hight 10,20 en 38 mm
Start and stop	Auto start/stop function end stop arc interruption by limit switch
Power	24V DC
Weight	7,5 kg (Tack) 10.0 kg (weaving)
Machine body	Aluminium